

Section 1

Technical Information

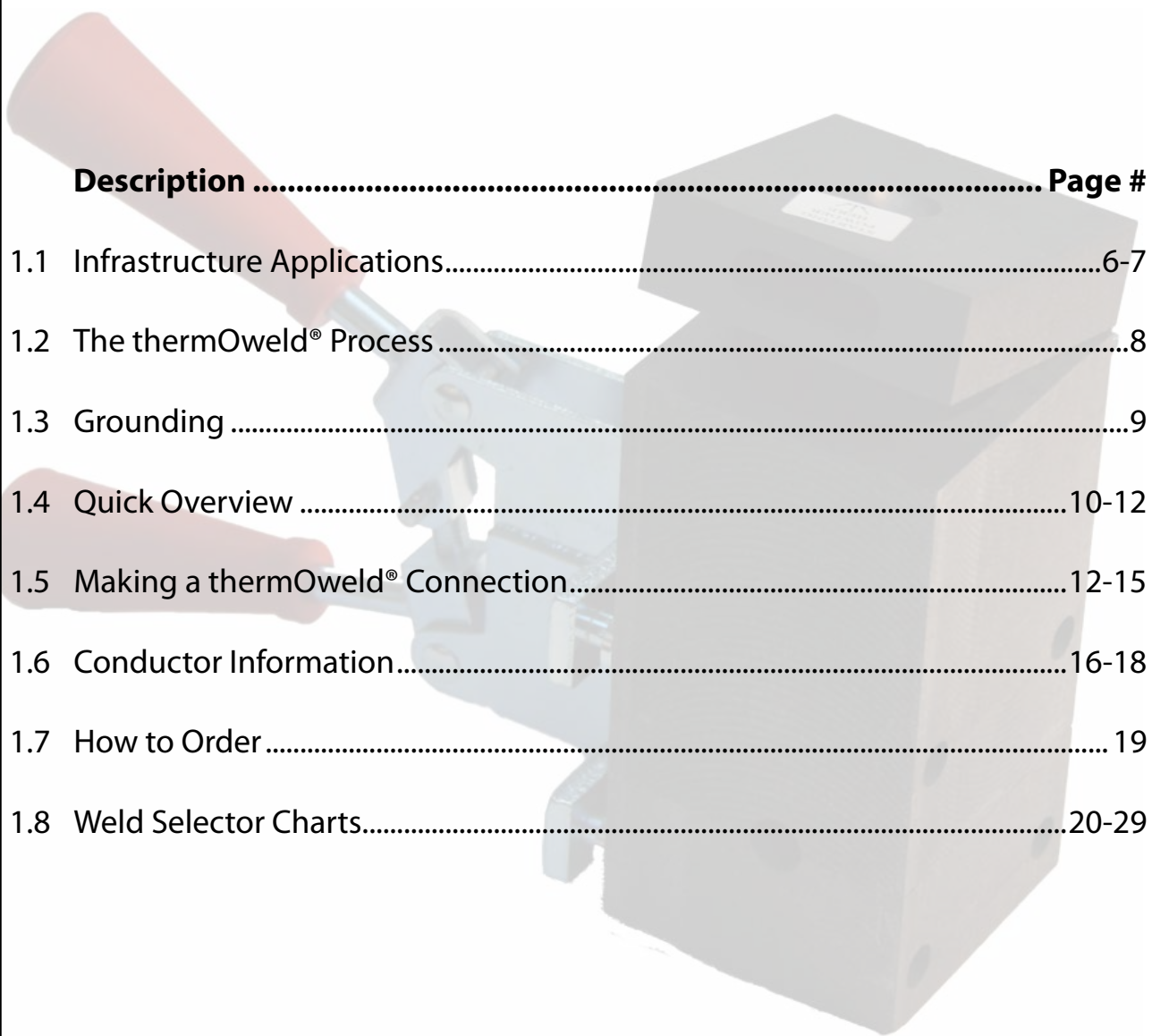

Description	Page #
1.1 Infrastructure Applications.....	6-7
1.2 The thermOweld® Process	8
1.3 Grounding	9
1.4 Quick Overview	10-12
1.5 Making a thermOweld® Connection.....	12-15
1.6 Conductor Information.....	16-18
1.7 How to Order	19
1.8 Weld Selector Charts.....	20-29

thermOweld® Infrastructure Applications

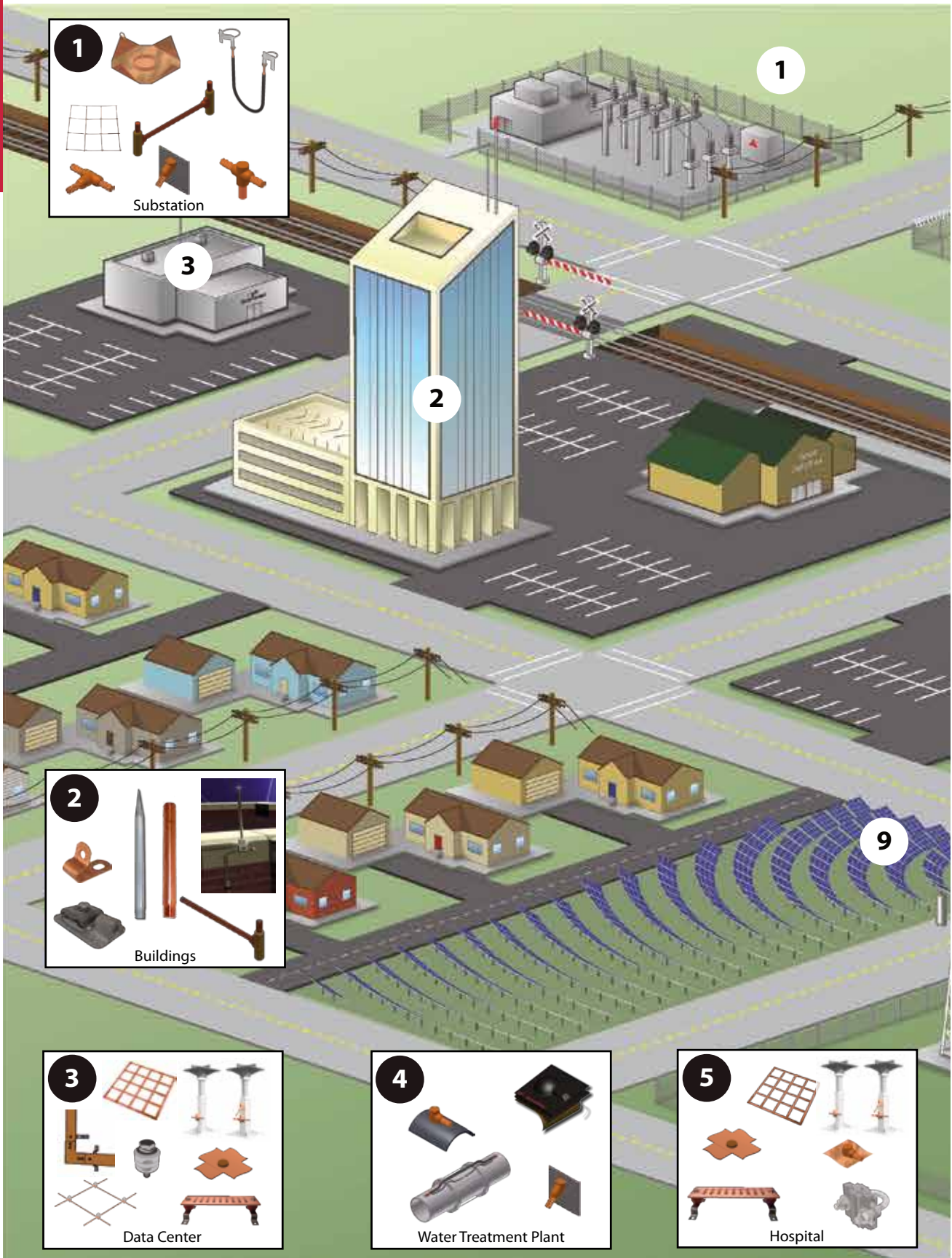

thermOweld® Infrastructure Applications

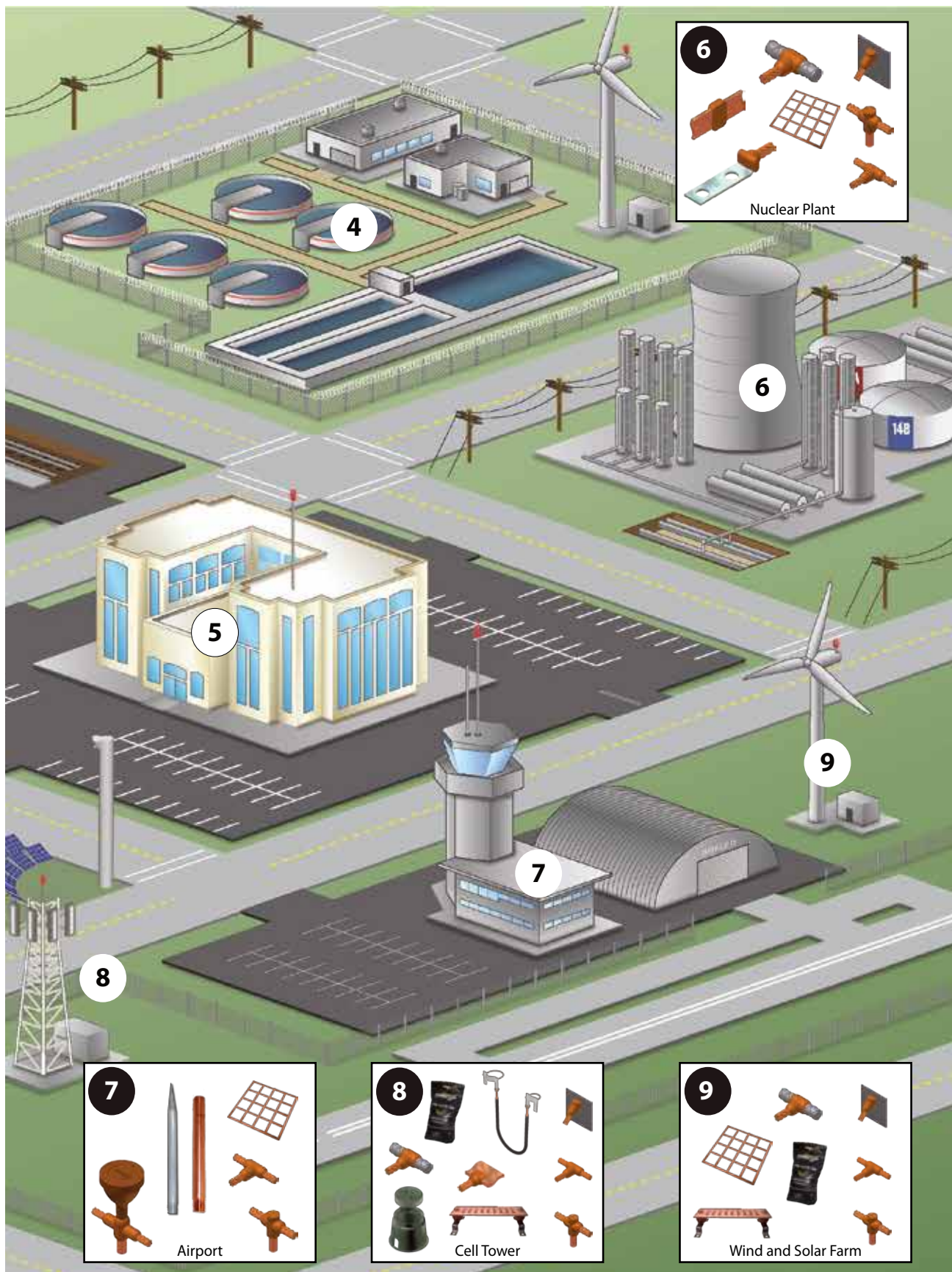

6

Nuclear Plant

7

Airport

8

Cell Tower

9

Wind and Solar Farm

The thermOweld® Process

The thermOweld® permanent-connection process has been engineered to be an easy and efficient field welding system. No outside power, bulky gas tanks or other equipment associated with welding are required with the thermOweld® system. Any field installer or contractor can use our high-grade graphite molds designed and produced in thermOweld's world-class volume CNC manufacturing operations.

Incorporating our EZ Lite® mold lid (see page 10), ignition is done safely from the top of the mold with limited exhaust emanating from the side vent. This innovation from thermOweld®, combined with other unique features, make even tight field installations possible. For indoor connections where desired, thermOweld® offers low-emissions molds as well. Contractors worldwide demand thermOweld® for ease of use and the safest operation.

Using thermOweld's superior weld metal (see page 132), a high-temperature reaction between special formulations of copper oxide and aluminum occurs in the mold crucible. Upon reaching critical temperature, the resulting molten copper drops into the weld cavity, instantly creating a high-temperature molecular bond with the conductor. This weld connection cools rapidly and the mold can be removed for the next connection with thermOweld's special off-set handle clamps (page 136). The thermOweld® process creates a superior connection without the excessive applied heat of brazing, arc welding or soldering. This is important especially for welding insulated cables or to thin-wall pipe.

The thermOweld® process creates a permanent, homogenous and molecular bond that cannot loosen or corrode. Compared to compression connectors, split bolts, crimp connectors, brazing and other connections, the thermOweld® connection is clearly superior. In fact, a thermOweld® connection will also withstand more current than the conductor itself.

It's easy to see why thermOweld® is The Contractor's Choice worldwide!

The thermOweld® process has been used to weld materials other than copper for electrical purposes, including:

Stainless Steel	Galvanized Steel*	Columbium	Kama	Brass	Chromax
Copperweld®	Silicon Bronze	Plain Steel	Steel Rail	Bronze	Cast Iron
Nichrome V	Copper-Clad Steel	Everdur®	Cor-Ten®	Niobium	Monel

*When welding to galvanized steel it is recommended to resurface exposed bare steel.

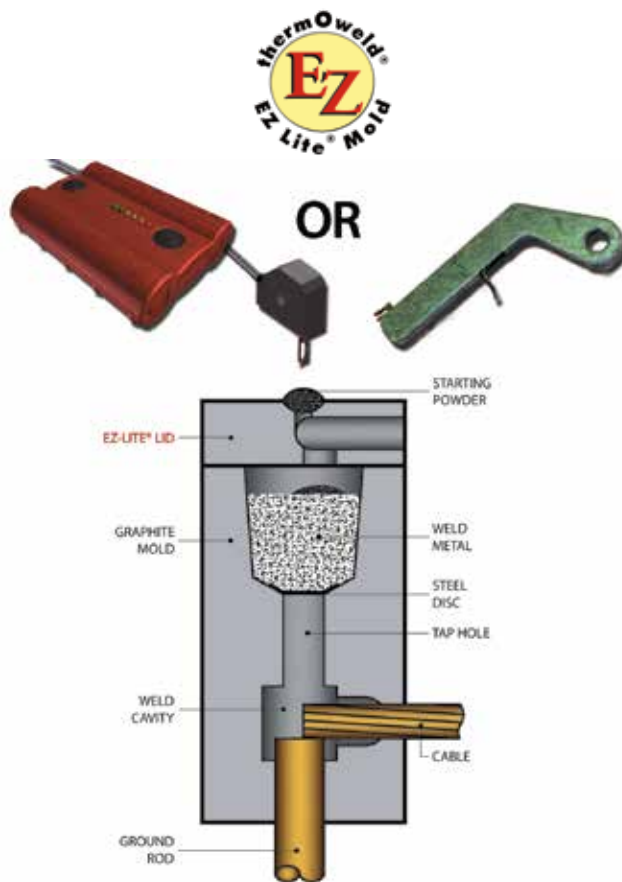

Standards Relating to thermOweld Designs of Earthing, Grounding and Lightning Protection

Standards	Country	Description
IEEE: 80-1986	USA, Australia, Asia, Europe, Latin America	Guide for Safety in AC Substation Grounding
IEEE: 837	USA, Australia, Asia, Latin America	Standard for Qualifying Permanent Connections used in Substation Grounding
IEEE: 81-1983	USA, Australia, Asia	Guide for Measuring Earth Resistivity, Ground Impedance and Earth Surface Potential of a Ground System
IEEE: 998-1996	USA, Australia, Asia	Guide for Direct Lightning Strike Shielding of Substations
UL-96	USA	Lightning Protection Components
UL 467	USA, Australia, Asia	Grounding and Bonding Equipment
NFPA 780	USA, Australia, Asia	Lightning Protection
NEC-250	USA, Canada	Grounding and Bonding National Electrical Code
TIA-607-B-2	Global	Telecom Grounding Bars and Products
IEC/TS 60479-1	Europe, Brazil	Effects of Current passing through human beings & livestock
EN62305-3: 2011	Europe	Protection against Lightning, Physical damage to structure and life hazard
ANCE NMJ-549-2005	Latin America	Lightning Protection

WHY IS GOOD GROUNDING IMPORTANT?

Good grounding (earthing) starts with a robust, durable, low-resistance connection between the earth and electrical equipment or electrical circuit ground. This necessary low-resistance connection insures the proper ground path for personnel safety and the proper functioning of electrical and electronic devices. Whether to present a good reference ground, direct a faulty circuit's potential to ground, or to dissipate an electrical surge or lightning strike, a uniform ground with the earth is essential in today's infrastructure.

Many factors, including soil resistivity, installation accessibility, layout and surrounding physical features must be taken into consideration when establishing a superior grounding system. On this page we highlight some key areas to consider in your grounding system and remind you that all electrical systems must be built in accordance with applicable codes and standards for your area.

GROUNDING PRINCIPLES

Low impedance is the key. All grounding connections should be as short and direct as possible to minimize inductance and reduce peak voltages induced in the connections. The ground electrode system must efficiently couple the ground by maximizing capacitive coupling to the soil. The resistance of the ground itself must also be minimized.

GROUND IMPEDANCE

Soil resistivity is an important design consideration. It varies markedly for different soil types, moisture content and temperatures and gives rise to variations in ground impedances.

SHORT, DIRECT GROUND CONNECTIONS

The voltage generated, especially by a lightning surge depends primarily on the rise time of the surge current and the impedance (primarily inductance of the path to ground). Extremely fast rise times result in significant voltage rises due to any series inductance resulting from long, indirect paths, or sharp bends in the routing of ground conductors.

COUPLING FROM THE ELECTRODE SYSTEM TO THE GROUND

The efficiency of a ground electrode system is dependent on a number of factors, including the geometry of the ground electrode system, the shape of the conductors and the effective coupling into the soil.

CHARACTERISTICS OF A GOOD GROUNDING SYSTEM

- Good electrical conductivity
- Conductors capable of withstanding high fault currents
- Long life - at least 40 years
- Low ground resistance and impedance

The basic philosophy of any grounding installation should be an attempt to maximize the surface area of electrodes or conductors with the surrounding soil. Not only does this help to lower the earth resistance of the grounding system, but it also greatly improves the impedance of the grounding system under lightning surge conditions.

- Equipotential bonding

Equipotential bonding helps ensure that hazardous potential differences do not occur between different incoming conductors such as metallic water services, power systems, telecommunications systems and the local ground, and also minimizes step and touch potentials.

- Good corrosion resistance

The ground electrode system should be corrosion resistant, and compatible with other conductors that are buried and bonded to the ground system. Copper is by far the most common material used for grounding conductors. In general, some form of maintenance or inspection procedure should be adopted to ensure the long-term effectiveness of a grounding system.

- Electrically and mechanically robust and reliable

Mechanical coupling can be used to join ground conductors, but suffers from corrosion effects when dissimilar metals are involved. As well as mechanical strength, thermOweld® connections provide excellent low impedance, long life electrical connections with excellent corrosion resistance.

thermOweld® EXOTHERMIC MOLDS

thermOweld® is a process of welding copper to copper, copper to steel and copper to ductile iron. The exothermic reaction takes place in a semi-permanent graphite mold with a special formula of copper oxide and aluminum.

thermOweld® connections are solid copper molecular bonds that do not loosen or corrode throughout the life of the host structure. These bonds are the superior connection method for the most reliable and highest longevity of grounding, lightning protection, cathodic protection and other critical infrastructure systems.

Standard Molds – thermOweld® standard molds are given in the tables on the pages in this catalog and are used with new clean AWG and Metric wire and cable. A standard mold is not for use in “heavy-duty” applications; see Heavy Duty Molds.

Heavy Duty Molds – thermOweld® heavy-duty molds are given in the tables on the pages in this catalog (with an H suffix) and are employed for use with reused or reclaimed and heavily oxidized AWG and Metric wire and cable. In these cases a “heavy-duty” mold is recommended as it accepts this larger wire diameter and utilizes a larger weld metal cartridge size. The resulting connection is larger than a standard mold connection. Note that the grounding engineer may determine that the calculated theoretical ground fault current level may be abnormally high and therefore would prefer the larger mass of a heavy-duty mold connection.

thermOweld® has designed and produced over 15,000 unique molds to meet application needs worldwide. We have solved many applications with unique and customized molds, utilizing our CAD engineering and specialized CNC machining capabilities. If you don't see what you need in this comprehensive catalog, contact us. We are ready to support you quickly!

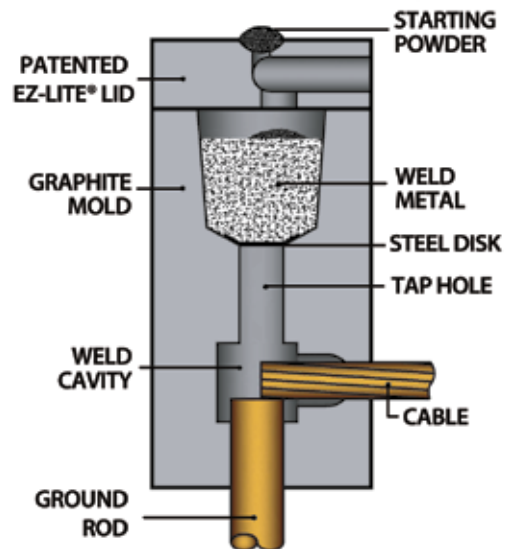

SINGLE SHOTS

thermOweld® single shot molds are an economical way to make cable connections onto the top of a ground rod or rebar. The single shot is a disposable single use ceramic mold that comes complete with everything required except the flint ignitor. This innovative process eliminates the need for a mold, handle clamps, and frames.



SUPERIOR WELD METAL

thermOweld® weld metal is packaged in moisture resistant plastic cartridges that have tight fitting caps. These cartridges and the necessary steel discs are then packaged in boxes that are shrink wrapped. Shrink wrapping ensures the weld metal will arrive in good condition, always dry, and ready for a positive ignition every time.

All weld metal is eligible for thermOweld's SDS (Same Day Service) shipment. Our SDS program is just like having it on your shelf.



GROUNDING & LIGHTNING PROTECTION PRODUCTS

Regardless of the requirements, thermOweld® provides a long list of products for your grounding needs. thermOweld® has the quickest lead-time in the industry. You may be surprised by what you find in this catalog to solve your grounding needs!



thermOweld® LOW EMISSIONS SYSTEM

thermOweld®'s Low Emission System reduces the emissions given off by our standard flint ignitor welding system. Our EZ Lite Remote® Electric Ignition System is another alternative to reduce exposure.

This system is designed with a special mold that utilizes a graphite felt filter (included in the weld metal package) in the lid of the mold; the emissions pass through and in turn create a semi closed system. Our Low Emission System uses our EZ Lite Remote® (see page 131) for ignition and our high quality thermOweld® weld powder less the standard starting powder. With all of these components, most of the visible smoke from the reacting weld powder is eliminated.

This system is currently available in all of thermOweld®'s standard configurations that use 200 gram or smaller cartridges. **To order molds:** replace the "M" in the mold number with "LE" (ex M-241 becomes LE-241). To order weld metal, place prefix "LE" in front of cartridge size (ex #115 becomes LE#115). For other sizes contact factory. The EZ Lite Remote® is our standard remote for this application.

This system is an excellent choice when welding is to be done in areas where minimal smoke and sparks are a necessity such as clean rooms, vaults, tunnels, computer rooms, and telecommunication facilities.

The Molecular Bond

The thermOweld® connection is a molecular weld. The weld has the same melting point as copper. This factor, along with the increased cross sectional area of the connection and insure the following:

- thermOweld® connections are not affected by a high current surge. Tests have shown that the electrical conductor will melt before the thermOweld® connection, when subjected to high short circuit current. Consult IEEE Standard 837.
- thermOweld® connections will not loosen or corrode at the point of weld. There are no contact surfaces or mechanical pressures involved.
- thermOweld® connections have a current-carrying capacity equal to or greater than that of the conductors.

The EZ Lite® Mold

- Makes all thermOweld® molds EZ to ignite.
- Lights from the top at any angle.
- Reduces emissions by 50% or more.
- Reduces splatter.
- Keeps the handle clamps clean and prolongs life.
- Added Safety - The EZ Lite® Lid points the exhaust away from the user.



INSTALLATION IS EASY!

Making a thermOweld® Connection

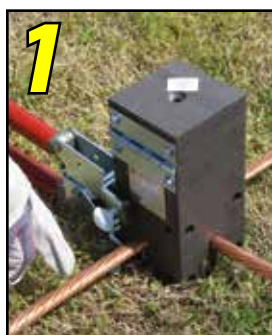

1
Position cleaned conductors in mold.



2
Place metal disc in bottom of mold crucible.



3
Pour powder into crucible.



4
Place a small amount of starting powder in the ignition pocket.



5
Ignite the starting powder with the Flint Ignitor.



6
Remove weld and clean mold before making next connection.

Visit www.thermOweld.com for training videos

INSTALLATION IS EASY!

Making a thermOweld® Connection using the EZ Lite Remote® Electric Start System



1
Position cleaned conductors in mold.



2
Place metal disc in bottom of mold crucible.



3
Pour powder into crucible.



4
Insert the EZ Lite® Ignitor in the connector.



5
Insert the EZ Lite® Ignitor in the top opening of the EZ Lite® Lid.



6
Turn the power button to the "ON" position.



7
Press the "Operate" button until the exothermic reaction is initiated.



8
Remove weld and clean mold before making next connection.

thermOweld's EZ Lite Remote® is the latest technological advance for thermOweld® exothermic products and the entire industry! For over 50 years, thermOweld® has been developing and inventing products and practical solutions that have become "The Contractor's Choice" worldwide.

With our patent-pending EZ Lite Remote®, the contractor, installer and distributor has versatility and ease-of-use in hand.

You can use your existing thermOweld® EZ Lite® molds and weld metal that you already have in your truck, the jobsite or on your shelf!

Visit www.thermOweld.com for training videos or scan the QR Code at the top of this page.

PIPE AND PLATE INSTALLATIONS ARE EASY! Making a thermOweld® Cable to Steel or Cast Iron Connection



1
Clean pipe before making weld.



2
Position conductor and mold onto pipe.



3
Place metal disc in bottom of mold.



4
Pour weld metal into mold.



5
Close lid and place starting powder on top. Ignite starting powder with Flint Ignitor.



6
Remove and clean mold before making next connection.

Visit www.thermOweld.com for training videos

INSTALLATION IS EASY!

Making a thermOweld® Low Emission Connection using the EZ Lite Remote® Electric Start System



1
Position cleaned conductors in mold.



2
Place filter pad into lid.



3
Place metal disc in bottom of mold crucible.



4
Pour powder into crucible.



5
Insert the EZ Lite® Ignitor in the connector.



6
Place EZ Lite® Ignitor on the side of the mold and place gasket on top of ignitor.



7
Close lid and secure with latch.



8
Turn the power button to the "ON" position.



9
Press the "Operate" button until the exothermic reaction is initiated.



10
Remove weld and clean mold before making next connection.

Visit www.thermOweld.com for training videos

TECHNICAL INFORMATION

CONDUCTOR IDENTIFICATION

Bare Class A, B, and C, Concentric Conductor
Based on ASTM Standard Specifications

Size AWG	Size in Circular Mills	Conductor Diameter	Number of wires				
			7	19	37	61	91
1000	1,000,000	1.152"			.1644*	.1280	.1048
800	800,000	1.031"			.1470*	.1145	.0938
750	750,000	.998"			.1424*	.1109	.0908
700	700,000	.964"			.1375*	.1071	.0877
600	600,000	.893"			.1273	.0992	.0812
500	500,000	.813"		.1622*	.1162	.0905	
400	400,000	.728"		.1451	.1040	.0810	
350	350,000	.681"		.1357	.0973	.0757	
300	300,000	.630"		.1257	.0900	.0701	
250	250,000	.575"		.1147	.0822	.0640	
4/0	211,600	.528"	.1739	.1055	.0756		
3/0	167,800	.470"	.1548	.0940	.0763		
2/0	133,100	.419"	.1379	.0837	.0600		
1/0	105,500	.373"	.1228	.0745	.0534		
1	83,690	.332"	.1093	.0664	.0467		
2	66,370	.292"	.0974	.0591			
3	52,630	.260"	.0867	.0526			
4	41,740	.232"	.0772	.0469			
6	26,240	.184"	.0612	.0372			
8	16,510	.146"	.0486	.0295			
10	10,380	.116"	.0385	.0234			
12	6,530	.0915"	.0305	.0185			
14	4,110	.0726"	.0242	.0147			

*Class AA

BARE SOLID COPPER WIRE

Based on ASTM
Standard Specifications

Size AWG	Size in Circular Mills	Conductor Diameter
4/0	211,600	.4600"
3/0	167,800	.4096"
2/0	133,100	.3648"
1/0	105,500	.3249"
1	83,690	.2893"
2	66,370	.2576"
3	52,630	.2294"
4	41,740	.2043"
6	26,240	.1620"
8	16,510	.1285"
10	10,380	.1019"
12	6,530	.0808"
14	4,110	.0641"

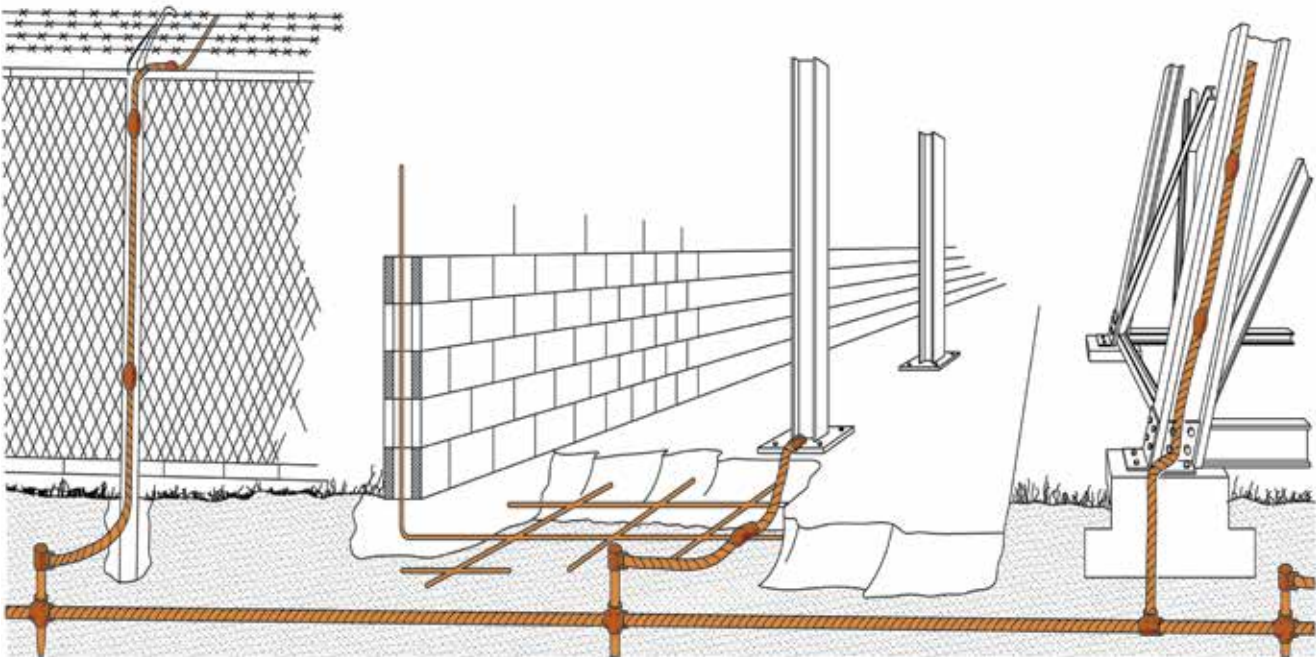

Some typical applications of thermOweld® connections in use.

GROUND RODS

Size	Material	Type	Body Diameter	Thread Size
1/2"	Copperclad	Sectional	.505"	9/16"
	Copperclad	Plain	.475"	
	Steel*	Plain	.500"	
5/8"	Copperclad	Sectional	.563"	5/8"
	Copperclad	Plain	.563"	
	Steel*	Plain	.625"	
3/4"	Copperclad	Sectional	.682"	3/4"
	Copperclad	Plain	.682"	
	Steel*	Plain	.750"	
1"	Copperclad	Sectional	.914"	1"
	Copperclad	Plain	.914"	
	Steel*	Plain	1.00"	

* Plain Steel, Stainless Steel, Stainless Clad Rods or Galvanized Steel

STEEL PIPE SIZES

Nominal Size Inches	O.D. Inches	Wall Thickness Inches	Standard Weight	ASTM A53-92-B
			(Schedule 40)	ANSI/ASME B36.10M-1985
1"	1.315	.133		
1 1/4"	1.660	.140		
1 1/2"	1.900	.145		
2"	2.375	.154		
2 1/2"	2.875	.203		
3"	3.500	.216		
3 1/2"	4.000	.226		
4"	4.500	.237		
5"	5.563	.258		
6"	6.625	.280		
8"	8.625	.322		
10"	10.750	.365		

CONCRETE REINFORCING BARS

US Imperial Sizes (Nominal Dimensions)

Rebar Sizes	Dia. Inches	Area - Sq. Inches
3	.375	.11
4	.500	.20
5	.625	.31
6	.750	.44
7	.875	.60
8	1.000	.79
9	1.128	1.00
10	1.270	1.27
11	1.410	1.56
14	1.693	2.25
18	2.257	4.00

COPPER-CLAD STEEL CONDUCTORS

Cable Stranding	Conductor Diameter	Size in Circular Mils
3/#10 CW	.220"	31,150
3/#9 CW	.247"	38,280
3/#8 CW	.277"	49,530
7/#10 CW	.306"	72,680
3/#7 CW	.311"	78,750
7/#9 CW	.343"	91,650
3/#6 CW	.349"	99,310
7/#8 CW	.385"	115,600
3/#5 CW	.392"	99,310
7/#7 CW	.433"	145,700
7/#6 CW	.486"	183,800
7/#5 CW	.546"	231,700
19/#9 CW	.572"	248,800
7/#4 CW	.613"	292,200
19/#8 CW	.642"	313,700
19/#7 CW	.721"	395,500
37/#9 CW	.801"	484,400
19/#6 CW	.810"	498,800
37/#8 CW	.899"	610,900
19/#5 CW	.910"	628,900
37/#7 CW	1.010"	770,300

RECTANGULAR COPPER BUSBAR

Thickness Inches	Width Inches	Circular Mil Size	Weight Lbs. Per Foot
1/8"	1"	159,200	.484
	1 1/2"	238,700	.726
	2"	318,300	.969
3/16"	1"	238,700	.727
	2"	477,500	1.45
1/4"	1"	318,300	.969
	1 1/2"	477,500	1.45
	2"	636,600	1.94
	3"	954,900	2.91
3/8"	4"	1,273,000	3.88
	1"	477,500	1.45
	1 1/2"	716,200	2.18
	2"	954,900	2.91
1/2"	3"	1,432,000	4.36
	4"	1,910,000	5.81
	2"	1,273,000	3.88
	3"	1,910,000	5.81
	4"	2,546,000	7.75

Useful Conversions

AREA
Sq.Inches x 1273 = kcmil
Sq.Millimetres x 1.974 = kcmil
kcmil x .5067 = Square Millimeters
DENSITY
Copper:
.323 lb/in ³
Steel:
.283 lb/in ³

METRIC TO IMPERIAL CABLE CONVERSION CHART

Cross Sectional Area (mm ²)	Conductor Diameter		Size A.W.G.	Conductor Diameter	
	inches	mm		inches	mm
2.0 Concentric	.071	1.8	#14 Concentric	.0726	1.84
3.5 Concentric	.095	2.4	#12 Concentric	.0915	2.3
4 Solid	.0984	2.5	#10 Solid	.102	2.6
6 Solid	.122	3.1	#8 Solid	.128	3.25
5.5 Concentric	.118	3.0	#10 Concentric	.116	2.95
8.0 Concentric	.142	3.6	#8 Concentric	.146	3.7
10 Solid	.150	3.8	#6 Solid	.162	4.1
10 Concentric	.162	4.2	#7 Concentric	.164	4.2
14 Concentric	.189	4.8	#6 Concentric	.184	4.7
16 Solid	.177	4.5	#4 Solid	.204	5.2
16 Concentric	.204	5.2	#5 Concentric	.205	5.2
22 Concentric	.236	6.0	#4 Concentric	.232	5.9
25 Solid	.220	5.6	#3 Solid	.229	5.8
25 Concentric	.260	6.4	#3 Concentric	.260	6.6
30 Concentric	.276	6.9	#2 Concentric	.292	7.4
35 Solid	.264	6.7	#2 Solid	.258	6.6
35 Concentric	.305	7.7	#2 Concentric	.292	7.4
38 Concentric	.315	7.8	#2 Concentric	.292	7.4
40 Concentric	.331	8.4	#1 Concentric	.332	8.4
50 Solid	.315	8.0	1/0 Solid	.325	8.3
50 Concentric	.354	9.0	1/0 Concentric	.373	9.5
55 Concentric	.378	9.6	1/0 Concentric	.373	9.5
60 Concentric	.394	10.0	2/0 Concentric	.419	10.6
70 Solid	.394	10.0	3/0 Solid	.410	10.4
70 Concentric	.430	10.9	2/0 Concentric	.419	10.6
80 Concentric	.453	11.5	3/0 Concentric	.470	12.0
95 Concentric	.505	12.6	4/0 Concentric	.528	13.4
100 Concentric	.512	13.0	4/0 Concentric	.528	13.4
120 Concentric	.567	14.2	250 MCM	.575	14.6
125 Concentric	.571	14.5	250 MCM	.575	14.6
150 Concentric	.634	16.1	300 MCM	.630	16.0
185 Concentric	.700	17.7	350 MCM	.681	17.3
200 Concentric	.717	18.2	400 MCM	.728	18.5
240 Concentric	.801	20.3	500 MCM	.813	20.7
250 Concentric	.815	20.7	500 MCM	.813	20.7
300 Concentric	.891	22.5	600 MCM	.893	22.7
325 Concentric	.922	23.4	700 MCM	.964	24.5
400 Concentric	1.03	26.2	800 MCM	1.031	26.2
500 Concentric	1.13	28.8	1000 MCM	1.152	29.3
600 Concentric	1.26	31.9	1200 MCM	1.263	32.1
625 Concentric	1.29	32.8	1250 MCM	1.289	32.7
725 Concentric	1.39	35.2	1400 MCM	1.364	34.6
800 Concentric	1.45	36.8	1600 MCM	1.459	37.1
850 Concentric	1.48	37.6	1700 MCM	1.506	38.2
1000 Concentric	1.64	41.6	2000 MCM	1.632	41.5

How to Order thermOweld® Molds

The most common **exothermic connections** for concentric and solid copper conductors are listed in this thermOweld® catalog. Save Time and Money by using molds listed in this catalog. If you cannot find the necessary connection please contact thermOweld® at **1-800-558-1373** or visit our web site at www.thermoweld.com and go to the **Mold Selection Wizard** for assistance.

1. Determine the Weld Type required:

- a. Know the application to determine what materials are to be welded.
- b. Refer to Selector Chart for correct weld type on pages 20-29.
- c. Find the appropriate Weld Type within the catalog.

There are pictures of each weld type in the upper corners of the catalog pages for easy reference

2. Determine the Correct Mold #:

- a. Determine the Conductor Size or Sizes, Ground Rod Size or surface to be welded.
- b. Locate each of the above to find the correct Mold #.

The thermOweld® catalog lists molds that are designed for stranded AWG concentric and solid cable, as well as ground rods, bus bar, lugs, steel, rebar, and other special grounding accessories. For sizes not listed please contact thermOweld® at 1-800-558-1373.

3. After Determining the Correct Mold # Verify the Following:

- a. Price Key - Find the price of the mold by crossing it on the thermOweld® price lists.
- b. Weld Metal (size) needed to make weld.
- c. Handle Clamps required for the mold.
- d. Packing Materials (if needed).
- e. See Notes - for other accessories needed or suggested to make this connection.

Please Check to make sure you have the following to make a proper weld:

- 1) Mold that fits your application.
- 2) Weld Metal required for the connection.
- 3) Handle Clamps or frame.
- 4) Flint Ignitor or EZ Lite Remote®- (Low emission molds require the use of the EZ Lite Remote®).
- 5) Sleeves, packing or other accessories required or suggested.

Mold Availability:

The mold availability is listed under the lead-time column in the catalog.

- SDS – Same Day Service (Orders placed by 4:00 pm Central time can ship Same Day)
- 2 - Ships 2 days following the date the order is placed.
- 4 - Will ship in 4 days ARO (Design molds will take up to 4 days to ship after receipt of order.)



Call Today ship Today!

SELECTOR CHART

NOTE: **Highlighted** weld types may be found in this catalog. Contact thermOweld® for more information about these and other weld types not listed.











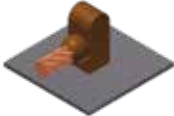
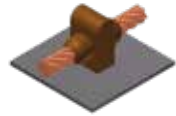







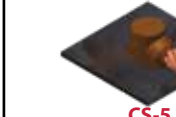





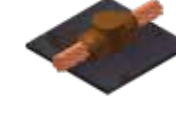



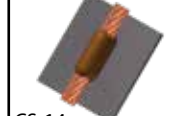













CABLE TO CABLE CONNECTIONS

 CC-1 SPLICE / HORIZONTAL Pages: 33, 85, 105, 217	 CC-12 SPLICE / HORIZONTAL 3/4" TO 5" CLEARANCE BEHIND CABLE	 CC-2 TEE / HORIZONTAL Pages: 34, 35, 86, 87, 88, 106, 218	 CC-3 TEE / VERTICAL TAP DOWN	 CC-4 CROSS (X) / HORIZONTAL TAP CABLE CUT Pages: 36, 37, 89, 107, 219	 CC-5 SPLICE / VERTICAL
 CC-6 PARALLEL TAP / HORIZONTAL (STACKED) Pages: 38, 85, 220	 CC-7 PARALLEL / HORIZONTAL RUN & TAP (STACKED) Pages: 39, 90, 221	 CC-8 HORIZONTAL / WYE (Y) LEFT HAND MOLD	 CC-9 HORIZONTAL / WYE (Y) RIGHT HAND MOLD	 CC-11 CROSS (X) / HORIZONTAL (UNCUT) Pages: 41, 91, 220	 CC-13 PARALLEL TAP / HORIZONTAL (SIDE-BY-SIDE)
 CC-14 PARALLEL / HORIZONTAL RUN & TAP (SIDE-BY-SIDE) Pages: 33, 198, 217	 CC-15 HORIZONTAL / WYE (Y) LEFT HAND MOLD 3/4" TO 5" CLEARANCE BEHIND CABLE	 CC-16 HORIZONTAL / WYE (Y) RIGHT HAND MOLD 3/4" TO 5" CLEARANCE BEHIND CABLE	 CC-17 VERTICAL / WYE (Y) TAP UP	 CC-18 VERTICAL / WYE (Y) TAP DOWN	 CC-19 HORIZONTAL / WYE (Y) TAP UP
 CC-20 HORIZONTAL / WYE (Y) TAP DOWN	 CC-21 CROSS (X) / HORIZONTAL TAP CABLE CUT	 CC-22 CROSS (X) / VERTICAL TAP CABLE CUT	 CC-23 CROSS (X) / VERTICAL (UNCUT)	 CC-24 TEE / HORIZONTAL TAP	 CC-25 TEE / VERTICAL TAP UP
 CC-26 ELL / HORIZONTAL	 CC-27 ELL / TAP DOWN	 CC-28 ELL / TAP UP	 CC-31 PARALLEL / VERTICAL TAP UP (SIDE-BY-SIDE)	 CC-32 PARALLEL / VERTICAL TAP UP (SIDE-BY-SIDE) 3/4" TO 5" CLEARANCE BEHIND CABLE	 CC-33 PARALLEL / VERTICAL TAP DOWN (SIDE-BY-SIDE)
 CC-34 PARALLEL / VERTICAL RUN & TAP (SIDE-BY-SIDE) Page: 40	 CC-29 DEAD END / HORIZONTAL (STACKED)	 CC-30 DEAD END / HORIZONTAL (SIDE-BY-SIDE)	 CC-35 DEAD END / VERTICAL (SIDE-BY-SIDE)	 CC-36 DEAD END / VERTICAL (SIDE-BY-SIDE)	 CC-37 SPLICE / HORIZONTAL MULTIPLE TAPS (SIDE-BY-SIDE)
 CC-38 SPLICE / VERTICAL MULTIPLE TAPS UP (SIDE-BY-SIDE)	 CC-39 SPLICE / VERTICAL MULTIPLE TAPS DOWN (SIDE-BY-SIDE)	 CC-40 TEE / HORIZONTAL TWO OR MORE TAP CABLES	 CC-41 TEE / HORIZONTAL TWO OR MORE RUN CABLES	 CC-42 TEE / HORIZONTAL TWO OR MORE RUN CABLES TWO OR MORE TAP CABLES	 CC-43 TEE / HORIZONTAL TWO OR MORE RUN CABLES TWO OR MORE TAP CABLES 3/4" TO 5" CLEARANCE BEHIND CABLE
 CC-44 TEE / VERTICAL TWO OR MORE RUN CABLES TWO OR MORE TAP CABLES	 CC-45 TEE / VERTICAL TWO OR MORE RUN CABLES TWO OR MORE TAP CABLES	 CC-46 CROSS (X) / HORIZONTAL TWO OR MORE RUN CABLES TWO OR MORE TAP CABLES	 CC-47 TEE / HORIZONTAL TWO OR MORE RUN CABLES	 CC-48 PARALLEL / HORIZONTAL RUN & TAP (SIDE BY SIDE)	 CC-49 PARALLEL / HORIZONTAL RUN & TAP (SIDE BY SIDE)
 CC-50 TEE / VERTICAL TWO OR MORE RUN CABLES					

SELECTOR CHART

NOTE: **Highlighted** weld types may be found in this catalog. Contact thermOweld® for more information about these and other weld types not listed.











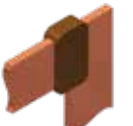
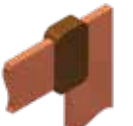











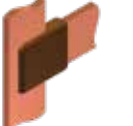









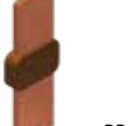
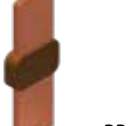





CABLE TO STEEL OR CAST IRON CONNECTIONS

 CS-1 HORIZONTAL CABLE THRU HORIZONTAL STEEL CABLE OFF SURFACE Pages: 53, 95, 113, 227	 CS-2 HORIZONTAL CABLE THRU HORIZONTAL STEEL CABLE OFF SURFACE Pages: 54, 96, 114, 228	 CS-42 HORIZONTAL CABLE THRU HORIZONTAL CAST IRON CABLE OFF SURFACE	 CS-3 VERTICAL CABLE 45° DOWN VERTICAL STEEL CABLE OFF SURFACE Pages: 55, 56, 97, 115, 212, 229	 CS-3 VERTICAL CABLE 45° DOWN VERTICAL STEEL PIPE CABLE OFF SURFACE	 CS-28 VERTICAL CABLE 45° DOWN VERTICAL CAST IRON CABLE OFF SURFACE
 CS-22 HORIZONTAL CABLE THRU HORIZONTAL STEEL	 CS-4 VERTICAL CABLE THRU VERTICAL STEEL CABLE OFF SURFACE Pages: 59, 100, 118	 CS-46 VERTICAL CABLE THRU VERTICAL CAST IRON CABLE OFF SURFACE	 CS-5 HORIZONTAL CABLE THRU HORIZONTAL CAST IRON CABLE ON SURFACE Page: 59	 CS-8 HORIZONTAL CABLE THRU HORIZONTAL STEEL CABLE ON SURFACE Pages: 53, 95, 113, 227	
 CS-6 HORIZONTAL CABLE THRU VERTICAL STEEL CABLE OFF SURFACE Pages: 60, 98, 117	 CS-43 HORIZONTAL CABLE THRU VERTICAL CAST IRON CABLE OFF SURFACE	 CS-7 VERTICAL CABLE UP VERTICAL STEEL CABLE ON SURFACE Pages: 61, 99, 118, 230	 CS-30 VERTICAL CABLE UP VERTICAL CAST IRON CABLE ON SURFACE	 CS-9 HORIZONTAL CABLE THRU HORIZONTAL STEEL CABLE ON SURFACE Pages: 54, 96, 114, 228	 CS-11 HORIZONTAL CABLE THRU HORIZONTAL CAST IRON CABLE ON SURFACE
 CS-18 HORIZONTAL CABLE THRU VERTICAL STEEL CABLE ON SURFACE SPECIFY RIGHT OR LEFT HAND MOLD Pages: 60, 100, 116	 CS-21 HORIZONTAL CABLE THRU VERTICAL CAST IRON CABLE ON SURFACE SPECIFY RIGHT OR LEFT HAND MOLD	 CS-12 VERTICAL CABLE DOWN 45° STEEL CABLE ON SURFACE	 CS-13 HORIZONTAL CABLE THRU 45° STEEL CABLE ON SURFACE	 CS-14 VERTICAL CABLE THRU 45° STEEL CABLE ON SURFACE	 CS-15 HORIZONTAL CABLE THRU 45° STEEL CABLE ON SURFACE
 CS-16 HORIZONTAL CABLE THRU HORIZONTAL STEEL PIPE CABLE OFF SURFACE	 CS-24 VERTICAL CABLE UP VERTICAL STEEL CABLE OFF SURFACE	 CS-23 VERTICAL CABLE DOWN VERTICAL STEEL CABLE OFF SURFACE Pages: 57, 58, 99, 206, 229	 CS-45 VERTICAL CABLE DOWN VERTICAL CAST IRON CABLE OFF SURFACE	 CS-25 VERTICAL CABLE DOWN VERTICAL STEEL CABLE ON SURFACE	
 CS-29 VERTICAL CABLE DOWN VERTICAL CAST IRON CABLE ON SURFACE	 CS-26 VERTICAL CABLE THRU VERTICAL STEEL CABLE ON SURFACE	 CS-27 HORIZONTAL CABLE THRU VERTICAL STEEL CABLE ON SURFACE Pages: 98, 117, 230	 CS-31 HORIZONTAL CABLE THRU VERTICAL STEEL CABLE OFF SURFACE SPECIFY RIGHT OR LEFT HAND MOLD	 CS-32 FOR CATHODIC PROTECTION HORIZONTAL CABLE THRU HORIZONTAL STEEL PIPE CABLE ON SURFACE Pages: 231, 232	 CS-33 FOR CATHODIC PROTECTION HORIZONTAL CABLE THRU HORIZONTAL CAST IRON PIPE CABLE ON SURFACE Pages: 233
 CS-34 FOR CATHODIC PROTECTION HORIZONTAL CABLE THRU HORIZONTAL STEEL PIPE CABLE ON SURFACE Pages: 234, 235	 CS-35 FOR CATHODIC PROTECTION HORIZONTAL CABLE THRU HORIZONTAL CAST IRON PIPE CABLE ON SURFACE Pages: 236	 CS-36 FOR CATHODIC PROTECTION VERTICAL CABLE 45° DOWN VERTICAL STEEL PIPE CABLE OFF SURFACE Pages: 237, 238	 CS-37 FOR CATHODIC PROTECTION VERTICAL CABLE 45° DOWN VERTICAL CAST IRON PIPE CABLE OFF SURFACE Pages: 239	 CS-38 FOR CATHODIC PROTECTION VERTICAL CABLE UP VERTICAL STEEL PIPE CABLE ON SURFACE	 CS-39 FOR CATHODIC PROTECTION VERTICAL CABLE UP VERTICAL CAST IRON PIPE CABLE ON SURFACE
 CS-47 VERTICAL CABLE 45° UP VERTICAL STEEL CABLE OFF SURFACE	 CS-48 FOR CATHODIC PROTECTION HORIZONTAL CABLE (FORMED) THRU HORIZONTAL STEEL PIPE CABLE ON SURFACE	 CS-49 FOR CATHODIC PROTECTION HORIZONTAL CABLE (FORMED) THRU HORIZONTAL CAST IRON PIPE CABLE ON SURFACE	 CS-50 FOR CATHODIC PROTECTION VERTICAL CABLE THRU VERTICAL STEEL PIPE CABLE ON SURFACE SPECIFY RIGHT OR LEFT HAND MOLD	 CS-51 FOR CATHODIC PROTECTION VERTICAL CABLE THRU VERTICAL CAST IRON PIPE CABLE ON SURFACE SPECIFY RIGHT OR LEFT HAND MOLD	 CS-52 VERTICAL CABLE THRU HORIZONTAL STEEL

SELECTOR CHART

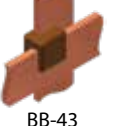
NOTE: **Highlighted** weld types may be found in this catalog. Contact thermOweld® for more information about these and other weld types not listed.

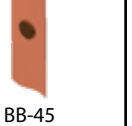







BUS BAR TO BUS BAR CONNECTIONS

 BB-1 HORIZONTAL SPLICE BARS ON EDGE Pages: 71, 247	 BB-28 HORIZONTAL SPLICE BARS ON EDGE 3/4" TO 5" CLEARANCE BEHIND BAR	 BB-2 ELL / TAP DOWN Pages: 72, 249	 BB-3 VERTICAL TEE / TAP DOWN BARS LAPPED Pages: 72, 248	 BB-8 VERTICAL TEE / TAP DOWN BARS LAPPED 3/4" TO 5" CLEARANCE BEHIND BAR	 BB-5 PARALLEL / BARS ON EDGE
 BB-4 VERTICAL TEE / TAP UP	 BB-11 VERTICAL TEE / TAP UP 3/4" TO 5" CLEARANCE BEHIND BAR	 BB-6 HORIZONTAL TEE BARS ON EDGE 3/4" TO 5" CLEARANCE BEHIND BAR	 BB-16 HORIZONTAL TEE BARS ON EDGE 3/4" TO 5" CLEARANCE BEHIND BAR	 BB-7 HORIZONTAL SPLICE BARS FLAT Page: 247	 BB-9 VERTICAL TEE / TAP DOWN MULTIPLE BARS
 BB-12 VERTICAL TEE / TAP DOWN	 BB-13 HORIZONTAL TEE BARS ON EDGE MULTIPLE BARS Page: 248	 BB-14 HORIZONTAL TEE BARS FLAT Page: 248	 BB-17 VERTICAL TEE TAP HORIZONTAL 3/4" TO 5" CLEARANCE BEHIND BAR	 BB-18 VERTICAL TEE TAP HORIZONTAL RIGHT HAND 3/4" TO 5" CLEARANCE BEHIND BAR	 BB-19 VERTICAL TEE TAP HORIZONTAL LEFT HAND 3/4" TO 5" CLEARANCE BEHIND BAR
 BB-15 HORIZONTAL TEE BARS FLAT MULTIPLE BARS Page: 248	 BB-20 VERTICAL ELL / TAP UP	 BB-21 HORIZONTAL ELL BARS ON EDGE 3/4" TO 5" CLEARANCE BEHIND BAR	 BB-22 HORIZONTAL ELL BARS FLAT Page: 248	 BB-23 HORIZONTAL ELL BARS FLAT MULTIPLE BARS Page: 248	 BB-24 VERTICAL ELL / TAP DOWN MULTIPLE BARS Page: 248
 BB-25 VERTICAL ELL / TAP UP MULTIPLE BARS Page: 248	 BB-26 HORIZONTAL ELL BARS ON EDGE MULTIPLE BARS Page: 248	 BB-27 VERTICAL SPLICE 3/4" TO 5" CLEARANCE BEHIND BAR	 BB-29 VERTICAL SPLICE 3/4" TO 5" CLEARANCE BEHIND BAR	 BB-30 HORIZONTAL SPLICE BARS ON EDGE MULTIPLE BARS Page: 248	 BB-31 HORIZONTAL SPLICE BARS FLAT MULTIPLE BARS Page: 248
 BB-32 VERTICAL SPLICE MULTIPLE BARS Page: 248	 BB-33 VERTICAL ELL / DOWN BARS FLAT Page: 248	 BB-34 HORIZONTAL SPLICE BARS FLAT MULTIPLE BARS Page: 248	 BB-35 HORIZONTAL SPLICE BARS ON EDGE MULTIPLE BARS Page: 248	 BB-36 HORIZONTAL SPLICE BARS FLAT MULTIPLE BARS Page: 248	 BB-38 VERTICAL SPLICE MULTIPLE BARS Page: 248
 BB-39 VERTICAL SPLICE BARS FLAT MULTIPLE BARS Page: 248	 BB-40 HORIZONTAL CROSS TAP CUT, BARS FLAT Page: 249	 BB-41 HORIZONTAL CROSS BARS UNCUT, BARS FLAT Page: 249	 BB-42 HORIZONTAL CROSS TAP CUT BARS ON EDGE Page: 249	 BB-43 VERTICAL CROSS BARS UNCUT Page: 249	 BB-44 HORIZONTAL BUTTON WELD FOR COPPER STRIP ONLY Page: 212
 BB-45 VERTICAL BUTTON WELD FOR COPPER STRIP ONLY Page: 212	 BB-46 HORIZONTAL BUTTON WELD FOR COPPER STRIP ONLY Page: 212				

SELECTOR CHART

NOTE: **Highlighted** weld types may be found in this catalog. Contact thermOweld® for more information about these and other weld types not listed.



















CABLE TO GROUND ROD OR ROD CONNECTIONS

 <p>CR-1 HORIZONTAL CABLE DEAD END VERTICAL GROUND ROD Pages: 42, 43, 92, 108, 222</p>	 <p>CR-2 HORIZONTAL CABLE THRU VERTICAL GROUND ROD Pages: 44, 45, 93, 109, 223</p>	 <p>CR-3 HORIZONTAL CABLE THRU VERTICAL GROUND ROD Pages: 46, 94, 110, 224</p>	 <p>CR-4 HORIZONTAL CABLE CROSS VERTICAL GROUND ROD</p>	 <p>CR-5 VERTICAL CABLE UP VERTICAL GRD ROD DOWN</p>	 <p>CR-6 VERTICAL CABLE DOWN VERTICAL GRD ROD UP</p>
 <p>CR-7 HORIZONTAL CABLE HORIZONTAL GRD ROD</p>	 <p>CR-8 HORIZONTAL CABLE THRU HORIZONTAL GRD ROD</p>	 <p>CR-9 HORIZONTAL CABLE THRU VERTICAL GRD ROD UP</p>	 <p>CR-11 HORIZONTAL CABLE CROSS (UNCUT) VERTICAL GROUND ROD</p>	 <p>CR-12 VERTICAL CABLE THRU UP HORIZONTAL GRD ROD</p>	 <p>CR-13 HORIZONTAL CABLE HORIZONTAL GRD ROD THRU</p>
 <p>CR-14 VERTICAL CABLE UP HORIZONTAL GRD ROD THRU</p>	 <p>CR-15 VERTICAL CABLE DOWN HORIZONTAL GRD ROD THRU</p>	 <p>CR-16 HORIZONTAL CABLE THRU VERTICAL GRD ROD THRU</p>	 <p>CR-17 HORIZONTAL PARALLEL CABLE (STACKED) VERTICAL GROUND ROD Page: 47</p>	 <p>CR-18 VERTICAL CABLE UP VERTICAL GRD ROD THRU Pages: 49, 111</p>	
 <p>CR-19 VERTICAL CABLE THRU VERTICAL GRD ROD THRU</p>	 <p>CR-20 VERTICAL CABLE DOWN VERTICAL GRD ROD THRU</p>	 <p>CR-21 HORIZONTAL CABLE THRU HORIZONTAL GRD ROD THRU (STACKED)</p>	 <p>CR-22 HORIZONTAL CABLE THRU HORIZONTAL GRD ROD THRU (STACKED)</p>	 <p>CR-23 HORIZONTAL CABLE THRU HORIZONTAL GRD ROD THRU (SIDE-BY-SIDE)</p>	 <p>CR-24 HORIZONTAL PARALLEL CABLE THRU (STACKED) VERTICAL GROUND ROD Page: 48</p>
 <p>CR-25 HORIZONTAL CABLE TEE VERTICAL GROUND ROD</p>	 <p>CR-26 HORIZONTAL CABLE THRU HORIZONTAL GRD ROD THRU</p>	 <p>CR-28 HORIZONTAL CABLE HORIZONTAL CHEMICAL GROUND ROD</p>	 <p>CR-33 HORIZONTAL CABLE THRU HORIZONTAL CHEMICAL GROUND ROD</p>	 <p>CR-34 VERTICAL CABLES UP VERTICAL GRD ROD DOWN</p>	 <p>CR-35 VERTICAL CABLE 45° DOWN VERTICAL GRD ROD THRU</p>
 <p>CR-36 VERTICAL CABLE 45° UP VERTICAL GRD ROD DOWN Page: 112</p>	 <p>CR-37 VERTICAL CABLE 45° DOWN VERTICAL CHEMICAL GROUND ROD</p>	 <p>CR-38 VERTICAL CABLE DOWN HORIZONTAL GRD ROD</p>	 <p>CR-39 HORIZONTAL CABLE - TEE HORIZONTAL CHEMICAL GROUND ROD</p>	 <p>CR-40 VERTICAL CABLES DOWN VERTICAL GROUND ROD UP</p>	 <p>CR-41 VERTICAL CABLES 45° UP VERTICAL GROUND ROD</p>

SELECTOR CHART

NOTE: **Highlighted** weld types may be found in this catalog. Contact thermOweld® for more information about these and other weld types not listed.

CABLE TO LUG OR BUS BAR CONNECTIONS

 <p>CB-1 HORIZONTAL CABLE HORIZONTAL LUG OR BAR Pages: 62, 101, 119, 206, 212, 244</p>	 <p>CB-2 VERTICAL CABLE UP HORIZONTAL BAR ON EDGE OVER 5" CLEARANCE BEHIND BAR Page: 65</p>	 <p>CB-6 VERTICAL CABLE UP HORIZONTAL BAR ON EDGE 3/4" TO 5" CLEARANCE BEHIND BAR Page: 66</p>	 <p>CB-3 VERTICAL CABLE DOWN HORIZONTAL BAR ON EDGE OVER 5" CLEARANCE BEHIND BAR Page: 67</p>	 <p>CB-7 VERTICAL CABLE DOWN HORIZONTAL BAR ON EDGE 3/4" TO 5" CLEARANCE BEHIND BAR Page: 68</p>	 <p>CB-4 HORIZONTAL CABLE HORIZONTAL BAR Pages 64, 245</p>
 <p>CB-5 HORIZONTAL CABLE THRU HORIZONTAL BAR Pages: 70, 246</p>	 <p>CB-8 HORIZONTAL CABLE HORIZONTAL BAR ON EDGE</p>	 <p>CB-9 VERTICAL CABLE DOWN VERTICAL BAR UP</p>	 <p>CB-11 VERTICAL CABLE UP VERTICAL BAR DOWN</p>	 <p>CB-12 MULTIPLE HORIZONTAL CABLES HORIZONTAL LUGS OR BARS</p>	 <p>CB-13 MULTIPLE HORIZONTAL CABLES MULTIPLE HORIZONTAL LUGS OR BARS</p>
 <p>CB-14 HORIZONTAL CABLE MULTIPLE HORIZONTAL LUGS OR BARS</p>	 <p>CB-15 HORIZONTAL CABLE VERTICAL BAR UP</p>	 <p>CB-16 VERTICAL CABLE UP HORIZONTAL BAR ON EDGE</p>	 <p>CB-17 VERTICAL CABLE DOWN HORIZONTAL BAR ON EDGE</p>	 <p>CB-18 HORIZONTAL CABLE VERTICAL BAR UP</p>	 <p>CB-19 HORIZONTAL CABLE VERTICAL BAR DOWN</p>
 <p>CB-20 HORIZONTAL CABLE VERTICAL BAR UP</p>	 <p>CB-21 HORIZONTAL CABLE VERTICAL BAR DOWN</p>	 <p>CB-22 HORIZONTAL CABLE HORIZONTAL BAR</p>	 <p>CB-23 VERTICAL CABLE UP HORIZONTAL BAR</p>	 <p>CB-24 VERTICAL CABLE DOWN HORIZONTAL BAR</p>	 <p>CB-25 HORIZONTAL CABLE HORIZONTAL BAR ON EDGE</p>
 <p>CB-26 HORIZONTAL CABLE THRU HORIZONTAL BAR ON EDGE</p>	 <p>CB-27 HORIZONTAL CABLE VERTICAL BAR UP</p>	 <p>CB-28 VERTICAL CABLE DOWN HORIZONTAL BAR ON EDGE</p>	 <p>CB-29 VERTICAL CABLE THRU HORIZONTAL BAR ON EDGE Page: 69</p>	 <p>CB-30 HORIZONTAL CABLE THRU VERTICAL BAR UP</p>	 <p>CB-31 HORIZONTAL CABLE THRU VERTICAL BAR DOWN</p>
 <p>CB-32 VERTICAL CABLE THRU HORIZONTAL BAR ON EDGE</p>	 <p>CB-33 HORIZONTAL CABLE HORIZONTAL LUG Pages: 63, 101, 244</p>	 <p>CB-34 HORIZONTAL CABLE HORIZONTAL COPPER STRIP THRU Page: 212</p>	 <p>CB-35 HORIZONTAL CABLE THRU HORIZONTAL COPPER STRIP THRU</p>	 <p>CB-36 VERTICAL CABLE DOWN HORIZONTAL BAR ON EDGE</p>	 <p>CB-37 HORIZONTAL CABLE HORIZONTAL BAR</p>
 <p>CB-38 VERTICAL CABLE DOWN HORIZONTAL BAR</p>					

SELECTOR CHART

NOTE: **Highlighted** weld types may be found in this catalog. Contact thermOweld® for more information about these and other weld types not listed.

CABLE TO REBAR CONNECTIONS

 CRE-1 PARALLEL / HORIZONTAL CABLE HORIZONTAL REBAR THRU Pages: 75, 255	 CRE-2 HORIZONTAL CABLE HORIZONTAL REBAR THRU Page: 76	 CRE-3 HORIZONTAL CABLE THRU VERTICAL REBAR THRU Pages: 77, 256	 CRE-4 HORIZONTAL CABLE THRU HORIZONTAL REBAR THRU Page: 78	 CRE-5 VERTICAL CABLE THRU HORIZONTAL REBAR THRU	 CRE-6 HORIZONTAL CABLE VERTICAL REBAR THRU Pages: 79, 257
 CRE-7 SPLICE / VERTICAL CABLE UP VERTICAL REBAR DOWN	 CRE-8 SPLICE / HORIZONTAL CABLE DOWN VERTICAL REBAR UP	 CRE-9 SPLICE / HORIZONTAL CABLE HORIZONTAL REBAR	 CRE-11 HORIZONTAL CABLE THRU HORIZONTAL REBAR	 CRE-12 VERTICAL CABLE THRU HORIZONTAL REBAR	 CRE-13 VERTICAL CABLE UP HORIZONTAL REBAR THRU
 CRE-14 VERTICAL CABLE DOWN HORIZONTAL REBAR THRU	 CRE-15 HORIZONTAL CABLE THRU VERTICAL REBAR UP	 CRE-16 HORIZONTAL CABLE THRU VERTICAL REBAR DOWN Page: 80, 94	 CRE-17 PARALLEL / HORIZONTAL CABLE THRU (STACKED) HORIZONTAL REBAR THRU	 CRE-18 PARALLEL / VERTICAL CABLE DOWN VERTICAL REBAR THRU	 CRE-19 PARALLEL / VERTICAL CABLE UP VERTICAL REBAR THRU
 CRE-20 PARALLEL / VERTICAL CABLE THRU VERTICAL REBAR THRU	 CRE-21 HORIZONTAL CABLE VERTICAL REBAR DOWN Page: 80	 CRE-25 HORIZONTAL CABLE TEE VERTICAL REBAR DOWN Page: 80	 CRE-35 VERTICAL CABLE 45° DOWN VERTICAL REBAR THRU		

BUS BAR TO REBAR CONNECTIONS

 BRE-3 HORIZONTAL BAR THRU BAR ON EDGE VERTICAL REBAR THRU	 BRE-4 HORIZONTAL BAR THRU HORIZONTAL REBAR THRU	 BRE-5 HORIZONTAL BAR THRU HORIZONTAL REBAR THRU	 BRE-6 HORIZONTAL BAR THRU BAR ON EDGE HORIZONTAL REBAR THRU	 BRE-7 VERTICAL BAR THRU HORIZONTAL REBAR THRU	 BRE-8 HORIZONTAL BAR BAR ON EDGE VERTICAL REBAR THRU Page: 257
 BRE-13 HORIZONTAL BAR FLAT HORIZONTAL REBAR	 BRE-15 VERTICAL BAR DOWN HORIZONTAL REBAR THRU	 BRE-16 HORIZONTAL BAR FLAT VERTICAL REBAR THRU	 BRE-17 HORIZONTAL BAR THRU BAR ON EDGE HORIZONTAL REBAR THRU	 BRE-18 VERTICAL BAR DOWN VERTICAL REBAR THRU	 BRE-20 VERTICAL BAR UP BAR ON EDGE VERTICAL REBAR THRU

ROD TO REBAR CONNECTIONS

REBAR TO REBAR CONNECTIONS











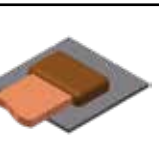
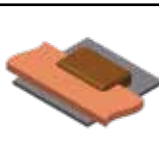

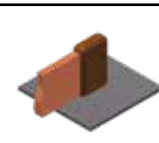
(NOTE: RE WELD TYPES ARE FOR ELECTRICAL CONTINUITY ONLY AND ARE NOT TO BE USED FOR STRUCTURAL PURPOSES.)

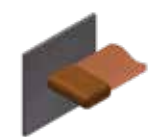
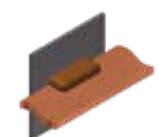
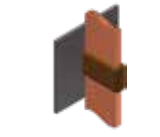
 RE-1 SPLICE / HORIZONTAL	 RE-2 SPLICE / VERTICAL	 RE-3 PARALLEL / VERTICAL RUN & TAP (SIDE-BY-SIDE)	 RE-7 PARALLEL / HORIZONTAL RUN & TAP (STACKED)	 RRE-1 HORIZONTAL ROD HORIZONTAL REBAR	 RRE-16 HORIZONTAL ROD VERTICAL REBAR THRU
--	--------------------------------------	--	---	--	--

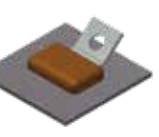







SELECTOR CHART

NOTE: **Highlighted** weld types may be found in this catalog. Contact thermOweld® for more information about these and other weld types not listed.

LUG OR BUS BAR TO STEEL CONNECTIONS

 BS-1 VERTICAL BAR DOWN VERTICAL STEEL Pages: 73, 250	 BS-2 HORIZONTAL BAR HORIZONTAL STEEL Pages: 73, 250	 BS-3 HORIZONTAL BAR THRU HORIZONTAL STEEL Pages: 74, 251	 BS-4 HORIZONTAL BAR THRU BAR ON EDGE VERTICAL STEEL Page: 74	 BS-5 VERTICAL BAR THRU VERTICAL STEEL Page: 74	 BS-6 HORIZONTAL BAR BAR ON EDGE HORIZONTAL STEEL
 BS-7 HORIZONTAL BAR THRU BAR ON EDGE HORIZONTAL STEEL	 BS-8 VERTICAL BAR DOWN BAR ON EDGE VERTICAL STEEL	 BS-9 HORIZONTAL BAR BAR ON EDGE VERTICAL STEEL	 BS-11 HORIZONTAL BAR THRU BAR ON EDGE VERTICAL STEEL	 BS-12 VERTICAL BAR THRU BAR ON EDGE VERTICAL STEEL	 BS-13 HORIZONTAL BAR BAR ON EDGE VERTICAL STEEL
 BS-14 VERTICAL BAR UP VERTICAL STEEL	 BS-15 HORIZONTAL 45° LUG HORIZONTAL STEEL	 BS-16 VERTICAL 45° LUG VERTICAL STEEL	 BS-17 HORIZONTAL 45° LUG LUG ON EDGE VERTICAL STEEL	 BS-18 HORIZONTAL BAR VERTICAL STEEL	 BS-19 HORIZONTAL BAR BAR ON EDGE VERTICAL STEEL
 BS-20 VERTICAL BAR UP BAR ON EDGE VERTICAL STEEL					











THREADED STUD OR ROD TO STEEL CONNECTIONS

 RS-1 HORIZONTAL STUD VERTICAL STEEL Pages: 52	 RS-2 VERTICAL STUD HORIZONTAL STEEL Pages: 52	 RS-5 VERTICAL ROD THRU VERTICAL STEEL ROD OFF SURFACE	 RS-6 HORIZONTAL ROD VERTICAL STEEL	 RS-7 VERTICAL ROD UP VERTICAL STEEL ROD ON SURFACE	 RS-8 HORIZONTAL ROD HORIZONTAL STEEL ROD ON SURFACE
 RS-9 HORIZONTAL ROD THRU HORIZONTAL STEEL ROD OFF SURFACE	 RS-11 HORIZONTAL ROD HORIZONTAL STEEL ROD OFF SURFACE	 RS-23 VERTICAL ROD DOWN VERTICAL STEEL ROD OFF SURFACE			



















SELECTOR CHART

NOTE: **Highlighted** weld types may be found in this catalog. Contact thermOweld® for more information about these and other weld types not listed.

GROUND ROD TO GROUND ROD CONNECTIONS

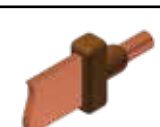
 RR-1 SPLICE / VERTICAL Pages: 52, 224	 RR-2 SPLICE / HORIZONTAL	 RR-3 HORIZONTAL ROD VERTICAL ROD THRU	 RR-4 HORIZONTAL ROD VERTICAL ROD DOWN	 RR-5 HORIZONTAL ROD THRU VERTICAL ROD THRU	 RR-6 HORIZONTAL ROD THRU VERTICAL ROD UP
 RR-7 PARALLEL / HORIZONTAL (STACKED)	 RR-13 HORIZONTAL ROD VERTICAL ROD	 RR-14 CROSS (X) / HORIZONTAL (UNCUT)	 RR-15 TEE / HORIZONTAL	 RR-16 ELL / HORIZONTAL	









BUS BAR TO GROUND ROD CONNECTIONS

 BR-1 HORIZONTAL BAR VERTICAL ROD Page: 252	 BR-2 HORIZONTAL BAR THRU BAR ON EDGE VERTICAL ROD Page: 253	 BR-3 HORIZONTAL BAR THRU BAR ON EDGE (UNCUT) VERTICAL ROD THRU Page: 254	 BR-4 HORIZONTAL BAR THRU HORIZONTAL ROD	 BR-5 HORIZONTAL BAR HORIZONTAL ROD THRU	 BR-6 HORIZONTAL BAR THRU BAR ON EDGE VERTICAL ROD UP
 BR-7 HORIZONTAL BAR THRU VERTICAL ROD Page: 254	 BR-8 HORIZONTAL BAR BAR ON EDGE VERTICAL ROD THRU	 BR-9 HORIZONTAL BAR THRU BAR ON EDGE VERTICAL ROD	 BR-11 VERTICAL SPLICE / BAR UP VERTICAL ROD	 BR-12 HORIZONTAL BAR BAR ON EDGE VERTICAL ROD	 BR-13 HORIZONTAL BAR HORIZONTAL ROD
 BR-14 VERTICAL BAR UP HORIZONTAL ROD	 BR-15 VERTICAL BAR DOWN HORIZONTAL ROD	 BR-16 HORIZONTAL LUG OR BAR HORIZONTAL ROD	 BR-17 HORIZONTAL BAR BAR ON EDGE HORIZONTAL ROD	 BR-18 HORIZONTAL BAR THRU VERTICAL ROD THRU	 BR-19 HORIZONTAL BAR THRU BAR ON EDGE VERTICAL ROD UP 3/4" TO 5" CLEARANCE BEHIND BAR
 BR-25 HORIZONTAL BAR VERTICAL ROD					

















SELECTOR CHART

NOTE: **Highlighted** weld types may be found in this catalog. Contact thermOweld® for more information about these and other weld types not listed.



AIRCRAFT GROUNDING RECEPTACLE CONNECTIONS

 <p>ABR-1 HORIZONTAL BAR BAR ON EDGE AIRCRAFT GROUNDING RECEPTACLE VERTICAL GROUND ROD</p>	 <p>AC-1 HORIZONTAL CABLE AIRCRAFT GROUNDING RECEPTACLE W/ RISER FOR PIPE Pages: 120, 127</p>	 <p>AC-2 HORIZONTAL CABLE THRU AIRCRAFT GROUNDING RECEPTACLE W/ RISER FOR PIPE Pages: 120, 127</p>	 <p>AR-1 AIRCRAFT GROUNDING RECEPTACLE VERTICAL ROD Page: 128</p>	 <p>ACR-1 HORIZONTAL CABLE AIRCRAFT GROUNDING RECEPTACLE VERTICAL ROD Page: 128</p>	 <p>ACR-2 HORIZONTAL CABLE THRU AIRCRAFT GROUNDING RECEPTACLE VERTICAL ROD Page: 128</p>
 <p>ARE-1 AIRCRAFT GROUNDING RECEPTACLE VERTICAL REBAR</p>	 <p>ACRE-1 HORIZONTAL CABLE AIRCRAFT GROUNDING RECEPTACLE VERTICAL REBAR</p>	 <p>ACRE-2 HORIZONTAL CABLE THRU AIRCRAFT GROUNDING RECEPTACLE VERTICAL REBAR</p>			

GROUNDING RECEPTACLE CONNECTIONS

 <p>CR-27 HORIZONTAL CABLE HORIZONTAL GROUND PLATE Page: 125</p>	 <p>CR-29 HORIZONTAL CABLE INVERTED GROUND PLATE</p>	 <p>CR-30 HORIZONTAL CABLE THRU HORIZONTAL GROUND PLATE Page: 125</p>	 <p>CR-31 HORIZONTAL CABLE VERTICAL GROUND PLATE W/ RISER FOR PIPE Page: 125</p>	 <p>CR-32 HORIZONTAL CABLE THRU VERTICAL GROUND PLATE W/ RISER FOR PIPE Page: 125</p>	 <p>BR-29 HORIZONTAL BAR INVERTED GROUND PLATE</p>
 <p>RS-3 HORIZONTAL GROUND PLATE VERTICAL STEEL Page: 124</p>	 <p>CRS-1 VERTICAL CABLE DOWN HORIZONTAL GROUND PLATE VERTICAL STEEL Page: 124</p>	 <p>CRS-2 VERTICAL CABLE UP HORIZONTAL GROUND PLATE VERTICAL STEEL Page: 124</p>	 <p>RR-8 HORIZONTAL ROD THRU HORIZONTAL GROUND PLATE</p>	 <p>RR-9 VERTICAL GROUND PLATE UP VERTICAL ROD DOWN</p>	 <p>RR-11 HORIZONTAL GROUND PLATE HORIZONTAL ROD</p>
 <p>RR-12 HORIZONTAL GROUND PLATE VERTICAL ROD THRU</p>	 <p>RRE-6 HORIZONTAL GROUND PLATE VERTICAL REBAR THRU</p>	 <p>RRE-8 HORIZONTAL GROUND PLATE HORIZONTAL REBAR THRU</p>	 <p>RRE-9 VERTICAL GROUND PLATE VERTICAL REBAR</p>	 <p>RRE-11 HORIZONTAL GROUND PLATE HORIZONTAL REBAR</p>	

















COPPER TUBE TO GROUND ROD CONNECTIONS

 <p>RT-1 HORIZONTAL TUBE VERTICAL GROUND ROD</p>	 <p>RT-2 HORIZONTAL TUBE THRU VERTICAL GROUND ROD</p>
--	---









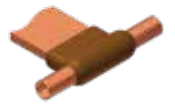

SELECTOR CHART

NOTE: **Highlighted** weld types may be found in this catalog. Contact thermOweld® for more information about these and other weld types not listed.











CABLE TO COPPER TUBE CONNECTIONS

 CT-1 HORIZONTAL CABLE THRU HORIZONTAL TUBE THRU	 CT-2 VERTICAL CABLE DOWN HORIZONTAL TUBE THRU	 CT-3 SPLICE HORIZONTAL	 CT-4 VERTICAL CABLE DOWN VERTICAL TUBE UP	 CT-5 VERTICAL CABLE UP VERTICAL TUBE DOWN	 CT-6 VERTICAL CABLE UP HORIZONTAL TUBE THRU
 CT-7 HORIZONTAL CABLE THRU VERTICAL TUBE DOWN	 CT-8 HORIZONTAL CABLE THRU VERTICAL TUBE UP	 CT-9 VERTICAL CABLE THRU HORIZONTAL TUBE	 CT-11 HORIZONTAL CABLE VERTICAL TUBE THRU	 CT-12 HORIZONTAL CABLE HORIZONTAL TUBE	 CT-13 VERTICAL CABLE DOWN HORIZONTAL TUBE
 CT-14 VERTICAL CABLE UP HORIZONTAL TUBE	 CT-15 HORIZONTAL CABLE VERTICAL TUBE DOWN	 CT-16 HORIZONTAL CABLE VERTICAL TUBE UP	 CT-17 HORIZONTAL CABLE THRU HORIZONTAL TUBE		

LUG OR BUS BAR TO COPPER TUBE CONNECTIONS

 TB-1 SPLICE / HORIZONTAL	 TB-2 SPLICE / HORIZONTAL BAR ON EDGE	 TB-3 HORIZONTAL BAR HORIZONTAL TUBE THRU	 TB-4 VERTICAL BAR DOWN HORIZONTAL TUBE THRU	 TB-5 HORIZONTAL BAR THRU BAR ON EDGE VERTICAL TUBE UP	 TB-6 HORIZONTAL BAR THRU BAR ON EDGE VERTICAL TUBE DOWN
 TB-7 HORIZONTAL BAR THRU BAR ON EDGE HORIZONTAL TUBE	 TB-8 VERTICAL BAR THRU HORIZONTAL TUBE	 TB-9 HORIZONTAL BAR THRU HORIZONTAL TUBE	 TB-11 HORIZONTAL BAR THRU VERTICAL TUBE UP	 TB-12 HORIZONTAL BAR THRU VERTICAL TUBE DOWN	

COPPER TUBE TO COPPER TUBE CONNECTIONS

 TT-1 SPLICE / HORIZONTAL	 TT-2 TEE / HORIZONTAL	 TT-3 ELL / HORIZONTAL	 TT-4 TEE / VERTICAL TAP DOWN	 TT-5 ELL / VERTICAL TAP DOWN	 TT-6 ELL / VERTICAL TAP UP
 TT-9 TEE / VERTICAL TAP UP	 TT-11 TEE / VERTICAL TAP HORIZONTAL	 TT-12 CROSS (X) / HORIZONTAL	 TT-13 SPLICE / VERTICAL		

TECHNICAL INFORMATION

thermOweld® provides high quality products to the Electric, Utility, Telecom, and Cathodic Markets.

The thermOweld® process is a simple way of welding copper to copper and copper to steel. The reaction takes place in a semi-permanent graphite mold and uses high temperature reactions of copper oxide and aluminum.

The thermOweld® connections are solid molecular bonds; they will not loosen or corrode throughout the life of the weld.

“If you need it, we can make it”

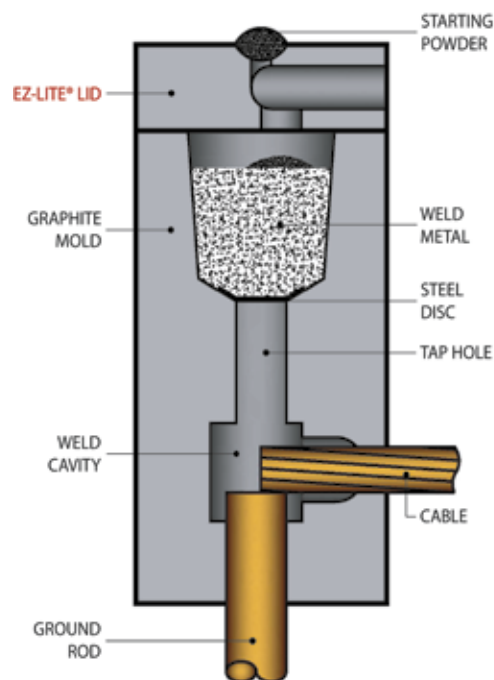

Features

- All thermOweld® molds come with our EZ Lite® lid.
- Added Safety - EZ Lite® Lid redirects exhaust away from the user.
- The average life of a mold is 50 plus welds - depending on the care and treatment it receives.
- EZ to ignite with the top ignition hole.
- EZ Lite® Lid extends the life of handles and framework of mold.
- Reduces emission by more than 50% compared to the standard lid.

